

PROJECT

»Gare de Nantes Sud«
Station Forecourt South
Nantes (F)

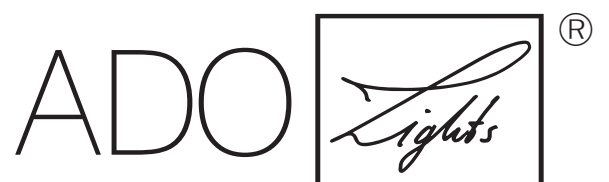

by TTC Timmler Technology

ILLUMINATED BENCHES STATION FORECOURT SOUTH



Nantes (F)

LIGHTING DESIGN

Atelier Coup d'Éclat, Paris

Light Interface

France is known for its »grands projets«. One of these is the construction of a completely new Nantes district between the railway station and the banks of the Loire.

As part of this major project, the railway station was also extensively renovated. It forms the interface between the old suburbs in the north and now opens up on the south side with a spacious, completely redesigned forecourt to the new district, which aims to bring the city closer to the river.

Following the already opened greened northern forecourt, a high quality of stay was thus also required in the southern part, because the square wants to be more than just a place of passage. The round and straight benches at the large beds with native trees are part of this concept.

They are fitted with continuous straight or curved light lines underneath the seating areas. In the dark, these bathe the square in pleasantly warm light, which is intended to give travellers, citizens and guest of the surrounding restaurants and hotels a feeling of safety.



ILLUMINATED BENCHES STATION FORECOURT SOUTH Nantes (F)

STATION FORECOURT SOUTH
Pictures



ILLUMINATED BENCHES STATION FORECOURT SOUTH

Nantes (F)

LIGHT LINES

Pictures + technical drawings

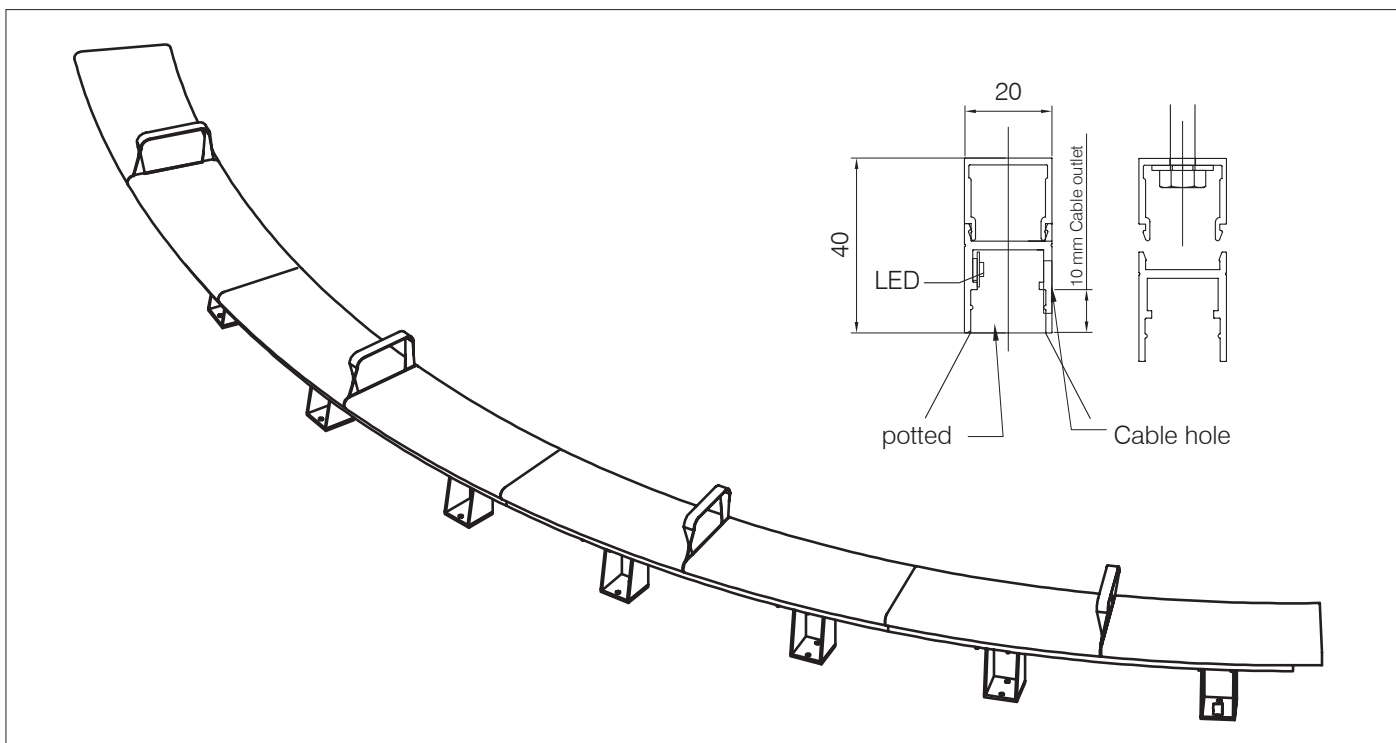

ILLUMINATED BENCHES STATION FORECOURT SOUTH

Nantes (F)

PAVABLE INSPECTION BOXES

Technical specifications + drawings

Light lines straight + curved versions

- approx. 21 metres LED Light Line LLF20.40, straight version for 7 benches, each 3040 mm long, in parts
- approx. 64 metres LED Light Line LLF20.40, curved version for 4 round benches, each 7517 mm long, in parts
- Aluminium profile, 20x40 mm [WxH], equipped with LED modules, white, 2200 K, dimmable, perfect light homogeneity without dark spots at the transitions

Inspection boxes

- 2 inspection boxes made of sheet metal 2 mm 1.4301, with drilled holes in the base and all-around in the bend, pavable cover

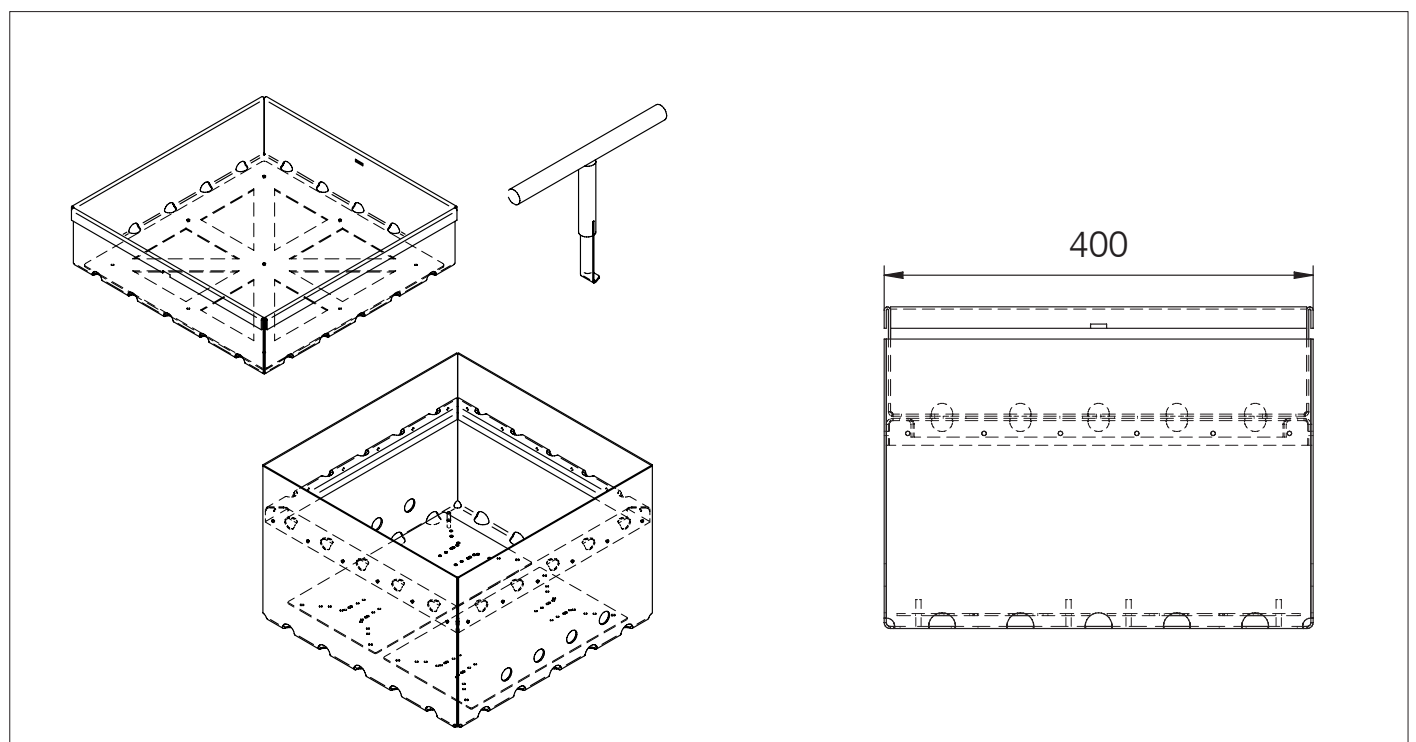
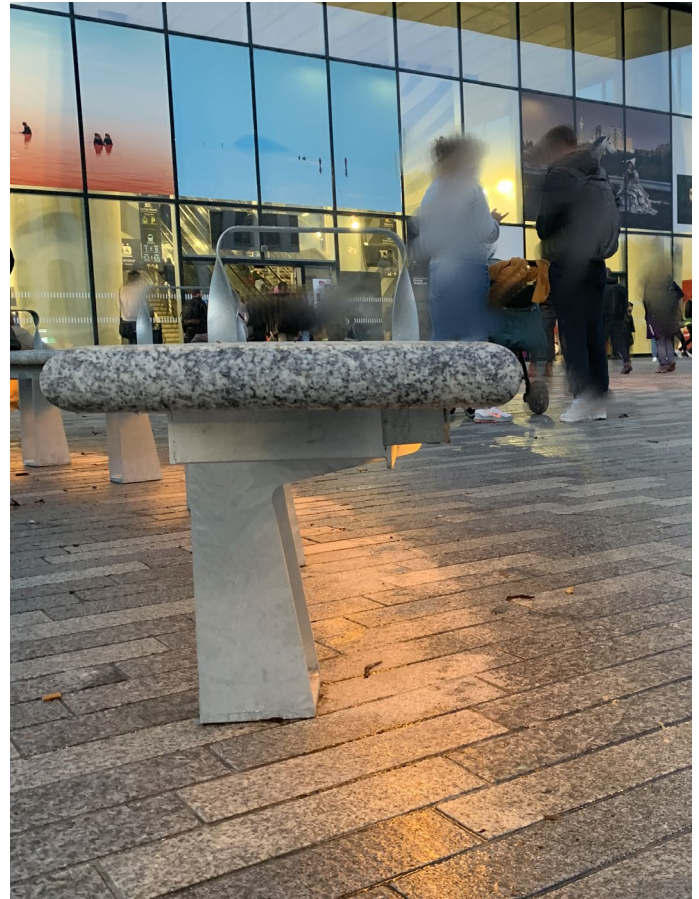

TTC Timmler Technology GmbH
Christian-Schäfer-Straße 8
D-53881 Flammersheim [Cologne/Bonn]
T +49 2255 9212-00
F +49 2255 9212-99
E info@ado-lights.com
I www.ado-lights.com
www.led-luc.com

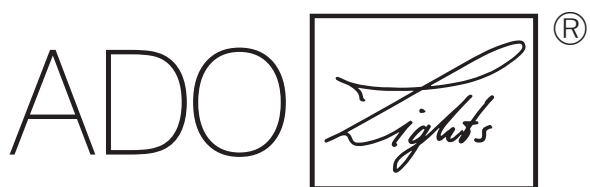

by TTC Timmler Technology

